



NFRC Thermal Simulations



Accredited Simulation Laboratory

With thousands of window, glass, spacer, and gas fill options available, finding the most efficient combination is important. Let us help you determine which options will provide the best thermal performance in your designs.

Performing thermal simulations will result in valuable information for your product development team.

- U-Value
- Condensation Resistance
- Solar Heat Gain Coefficient
- Visible Transmittance

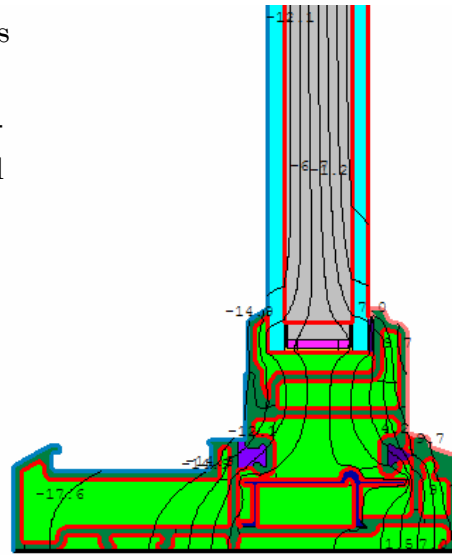

The staff at Quast Consulting and Testing Inc. is pleased to announce our accreditation as an NFRC Thermal Simulation Laboratory. We pride ourselves on providing our customers with the most accurate and efficient services possible. Let us help you with your product certification or research and development needs. Please contact us for a quote.



Brian Sasman P.E.

Ph: 715-302-1934

email: bsasman@qcandt.com

Rhonda Schotz

Ph: 715-551-4662

email: rschotz@qcandt.com

Adding quality and value to every project!

P.O. Box 241
1055 Indianhead Drive
Mosinee, WI 54455

Phone: 715-693-8378
Fax: 715-693-0689
website: www.qcandt.com